



GAI-TRONICS® CORPORATION
A HUBBELL COMPANY

PVC Coil Cord Replacement Kit

Models 12514-007, 12514-008, and 12514-009

Confidentiality Notice

This manual is provided solely as an operational, installation, and maintenance guide and contains sensitive business and technical information which is confidential and proprietary to GAI-Tronics. GAI-Tronics retains all intellectual property and other rights in or to the information contained herein, and such information may only be used in connection with the operation of your GAI-Tronics product or system. This manual may not be disclosed in any form, in whole or in part, directly or indirectly, to any third party.

General Information

These kits are for use on the following models:

- 240 • 250 • 611 • 701-201 • 701-205 • 7165-002
- 246 • 256 • 6115 • 701-202 • 711-002 • 726-101
- 247 • 257 • 616 • 701-203 • 7115-002 • 7265-101
- 248 • 258 • 6165 • 701-204 • 716-002

This kit includes the following components:

Qty	Description
1	Strain-relief Bushing
1	6-foot PVC cord (Kit 12514-007 only)
1	15-foot PVC cord (Kit 12514-008 only)
1	25-foot PVC cord (Kit 12514-009 only)

Installation

Models 240, 246, 247, 248, 250, 256, 257, 258

Removal of old cord

1. Loosen and remove the screws securing the front panel. Pull the front panel assembly away from the back enclosure.
2. Disconnect the modular telephone line from the PC board. Disconnect the four handset wires from the PC board.
3. When replacing a PVC cord, use a Heyco® bushing tool, or a set of needlenose pliers, to squeeze the notch on the front panel side of the strain relief bushing and pull out the bushing.

4. When replacing a thermoplastic elastomer cord, remove the C-clip securing the bushing and the cord to the rear of the front panel assembly.
5. Pull the old cord through the front panel assembly.
6. Remove the lower cap from the handset. Lift out the transmitter and disconnect both wires.
7. Remove the receiver cap, lift out the receiver and disconnect both wires.
8. Pull the wire harness out of the handset and discard the cord.

Installation of the new cord

1. Insert the wire harness from the new cord into the handset.
2. Snip off the blue and yellow wires as close to their origin as possible. Connect the red and green wires to the receiver. Replace the receiver and the receiver cap.

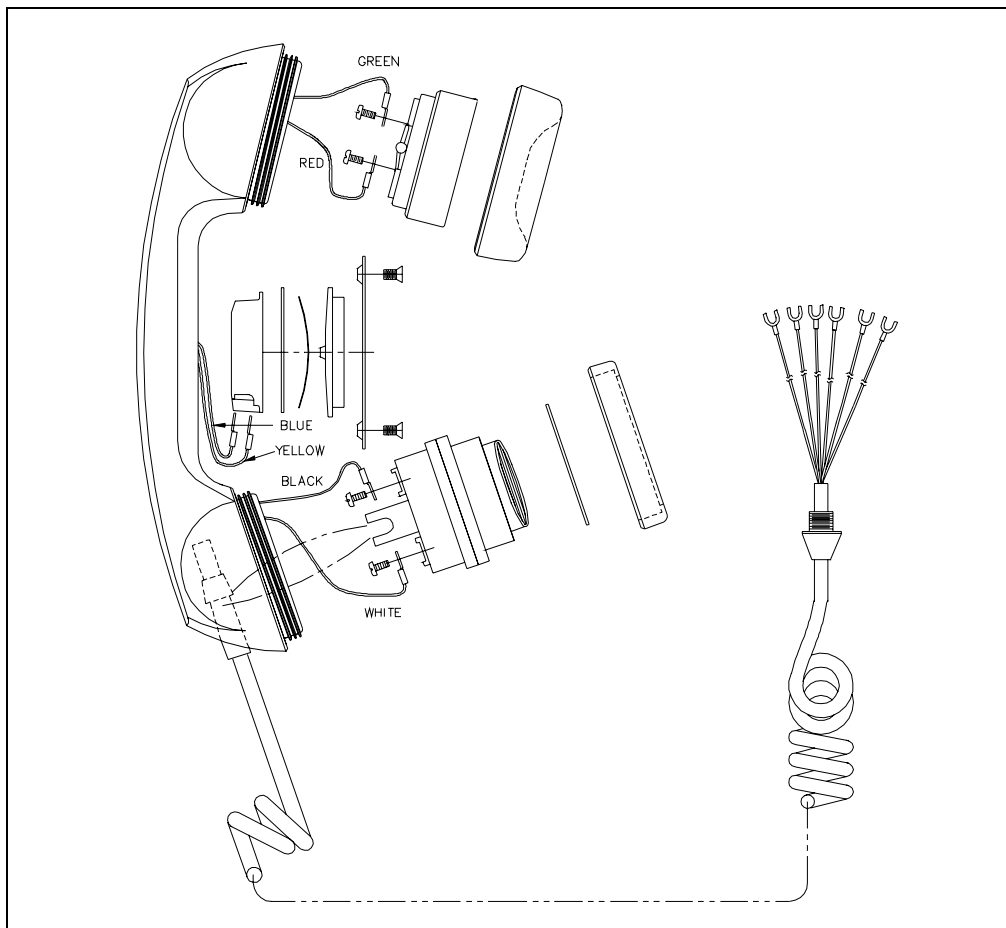

Figure 1. Handset Assembly with Pressbar

3. Connect the black and white wires to the transmitter. Replace the transmitter, transmitter cup, and cap. Refer to Figure 1. Note the notch on the transmitter. When placing the transmitter in the handset, align the notch to catch the bushing on the coil cord to secure the cord firmly in the handset.
4. Insert the end of the new cord through the front panel assembly until the bushing is flush against the panel.

5. Press the bushing tight against the front panel, and insert the C-clip on the rear of the bushing on the back side of the front panel assembly, or use a Heyco® bushing tool to squeeze the Heyco® bushing back into the front panel opening.
6. Reconnect the four telephone wires to the PC board in this manner: red to E1; green to E2; white to E3; black to E4.
7. Reconnect the modular telephone wire to the RJ11 jack on the PC board and fasten the front panel assembly to the rear enclosure.

Models 701-201, 701-202, 701-203, 701-204, and 701-205

Removal of old cord

1. Unscrew the four front panel screws and remove the handset amplifier from the enclosure.
2. Unscrew the handset transmitter cap and lift out the transmitter.
3. Disconnect the wires from the transmitter.
4. Unscrew the receiver cap. Lift out the receiver.
5. Disconnect the red and green wires from the handset PC board. For stations with a pressbar handset, proceed to Step 6. For stations without a pressbar handset, proceed to Step 8.
6. Loosen the two screws securing the pressbar. Lift off the metal retainer, plastic pressbar, curved spring and plunger.
7. Lift out the rectangular plastic cup and disconnect the blue and yellow wires.
8. Pull the old cord out of the handset. Place the amplifier to easily access the rear of the unit.
9. Loosen the four screws securing the backbox to the amplifier. The backbox will still be connected to the amplifier. Carefully separate the two pieces.
10. Disconnect the yellow (E5), blue (E6), red (E4), white (E1), black (E2) and green (E3) wires from the PC board. Stations without pressbar handsets will not have the blue and yellow wires.
11. Using a Heyco® bushing tool or needlenose pliers, pull the bushing and the cord through the front panel and discard.

Installation of new cord

1. Feed the red and green wires through the transmitter end of the handset, through the center of the handset receiver end. Place the brass eyelets on the receiver as indicated in Figure 2. Feed the screws through the handset PCBA through the eyelet and into the receiver. Secure the wires as indicated in Figure 2.
2. Place the receiver in the cup. Tighten the receiver cap. For stations with a pressbar handset, proceed to Step 3. For stations without a pressbar handset, proceed to Step 8.
3. Feed the yellow and blue wires through the handset to the pressbar area.
4. Secure the wires to the terminals in the plastic cup. Place the plastic cup in the handset.
5. See Figure 1 above. Place the copper piece with the rubber center in first, with the solid rubber side facing up and the notch in the appropriate slot.
6. Place the other copper piece so that the bend faces out.
7. Place the plastic piece such that the GTC logo side is facing up. Place the metal bracket on top and tighten the screws.
8. **FOR HANDSETS WITHOUT A PRESSBAR ONLY:** Snip off the blue and yellow wires as close to their origin as possible.
9. Attach the wires to the transmitter terminals.
10. Place the transmitter in the transmitter cap, making sure that the cord guide snaps firmly onto the cord to secure it. Screw on the transmitter cap.
11. Feed the end of the cord through from the front panel of the phone and use the Heyco® bushing tool or needlenose pliers to secure the bushing on the amplifier front.
12. Connect the wires to the PC board: red to E4, white to E1, black to E2, yellow to E5, blue to E6 and green to E3. Stations without pressbar handsets will not have the blue and yellow wires.
13. Secure the backbox by tightening the four screws.
14. Reinstall the amplifier into the enclosure.

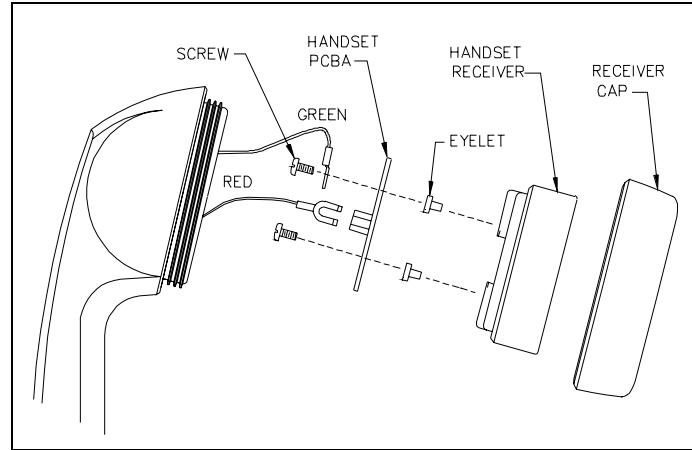

Figure 2. Receiver Detail for 701 Models

Models 711-002, 7115-002, 611C, and 6115

Removal of old cord

1. Remove the two mounting screws from the mounting bracket. Remove the subset from the mounting bracket.
2. Remove the four screws on the left side of the unit.
3. Locate the PC board. On the side closest to you, you will see the six handset wires. Unplug all six of the wires.
4. Use a Heyco® bushing tool to remove the bushing securing the cord to the subset. Pull the cord through the hole and remove.
5. At the handset end, unscrew the transmitter cap, lift out the transmitter and disconnect the wires.
6. Unscrew the receiver cap, lift out the receiver and disconnect the red and green wires from the receiver.
7. **FOR HANDSETS WITH PRESSBAR ONLY:** Loosen the two screws securing the pressbar. Lift off the metal retainer, plastic pressbar, curved spring and plunger. Lift out the rectangular plastic cup and disconnect the blue and yellow wires.
8. Pull the old cord out of the handset and discard.

Installation of new cord

1. Feed the red and green wires through the transmitter end of the handset, through the center of the handset to the receiver end. Secure the wires to the receiver.
2. Place the receiver in the cup. Tighten the receiver cap.
3. **FOR HANDSETS WITH PRESSBAR ONLY:** Feed the yellow and blue wires through the handset to the pressbar area. Secure the wires to the terminals in the plastic cup. Place the plastic cup in the handset. Refer to Figure 1. Place the copper piece with the rubber center in first, with the solid rubber side up. Install the curved spring. Place the plastic pressbar in with the GTC logo side up. Place the metal bracket on top. Tighten the screws.
4. Attach the black and white wires to the transmitter terminals.
5. Place the transmitter in the transmitter cup, making sure that the cord guide snaps firmly onto the cord to secure it. Screw on the transmitter cap.
6. Feed the other end of the cord through from the front panel of the phone and use a Heyco® tool or needlenose pliers to secure the bushing on the front of the subset.
7. Reconnect the wires to the PC board according to the labels on the board.
8. Replace the four screws to reassemble the unit.
9. Use the two mounting screws to secure the subset to the mounting bracket.

Models 616C, 6165, 716-002, and 7165-002

Removal of old cord

1. Remove the unit from the wall or mounting surface.
2. Remove the four back panel screws.
3. Follow Steps 3 through 7 under “Removal of old cord” in the section for 611C, 6115, 711-002, and 7115-002 above.

Installation of new cord

1. Follow Steps 1 through 7 under “Installation of new cord” in the section for 611C, 6115, 711-002, and 7115-002 above.
2. Replace the four back panel screws.
3. Remount the unit.

Models 726 and 7265-101

Removal of old cord

1. Loosen the four screws securing the housing to the base.
2. Hinge the housing forward to access the inside of the subset.
3. Follow Steps 3 through 7 under “Removal of old cord” in the section for 611C, 6115, 711-002, and 7115-002 above.

Installation of new cord

1. Follow Steps 1 through 7 under “Installation of new cord” in the section for 611C, 6115, 711-002, and 7115-002 above.
2. Place the housing on the base and tighten the four screws.

Warranty

Equipment. GAI-Tronics warrants for a period of one (1) year from the date of shipment, that any GAI-Tronics equipment supplied hereunder shall be free of defects in material and workmanship, shall comply with the then-current product specifications and product literature, and if applicable, shall be fit for the purpose specified in the agreed-upon quotation or proposal document. If (a) Seller's goods prove to be defective in workmanship and/or material under normal and proper usage, or unfit for the purpose specified and agreed upon, and (b) Buyer's claim is made within the warranty period set forth above, Buyer may return such goods to GAI-Tronics' nearest depot repair facility, freight prepaid, at which time they will be repaired or replaced, at Seller's option, without charge to Buyer. Repair or replacement shall be Buyer's sole and exclusive remedy. The warranty period on any repaired or replacement equipment shall be the greater of the ninety (90) day repair warranty or one (1) year from the date the original equipment was shipped. In no event shall GAI-Tronics warranty obligations with respect to equipment exceed 100% of the total cost of the equipment supplied hereunder. Buyer may also be entitled to the manufacturer's warranty on any third-party goods supplied by GAI-Tronics hereunder. The applicability of any such third-party warranty will be determined by GAI-Tronics.

Services. Any services GAI-Tronics provides hereunder, whether directly or through subcontractors, shall be performed in accordance with the standard of care with which such services are normally provided in the industry. If the services fail to meet the applicable industry standard, GAI-Tronics will re-perform such services at no cost to buyer to correct said deficiency to Company's satisfaction provided any and all issues are identified prior to the demobilization of the Contractor's personnel from the work site. Re-performance of services shall be Buyer's sole and exclusive remedy, and in no event shall GAI-Tronics warranty obligations with respect to services exceed 100% of the total cost of the services provided hereunder.

Warranty Periods. Every claim by Buyer alleging a defect in the goods and/or services provided hereunder shall be deemed waived unless such claim is made in writing within the applicable warranty periods as set forth above. Provided, however, that if the defect complained of is latent and not discoverable within the above warranty periods, every claim arising on account of such latent defect shall be deemed waived unless it is made in writing within a reasonable time after such latent defect is or should have been discovered by Buyer.

Limitations / Exclusions. The warranties herein shall not apply to, and GAI-Tronics shall not be responsible for, any damage to the goods or failure of the services supplied hereunder, to the extent caused by Buyer's neglect, failure to follow operational and maintenance procedures provided with the equipment, or the use of technicians not specifically authorized by GAI-Tronics to maintain or service the equipment. **THE WARRANTIES AND REMEDIES CONTAINED HEREIN ARE IN LIEU OF AND EXCLUDE ALL OTHER WARRANTIES AND REMEDIES, WHETHER EXPRESS OR IMPLIED BY OPERATION OF LAW OR OTHERWISE, INCLUDING ANY WARRANTIES OF MERCHANTABILITY OR FITNESS FOR A PARTICULAR PURPOSE.**

Return Policy

If the equipment requires service, contact your Regional Service Center for a return authorization number (RA#). Equipment should be shipped prepaid to GAI-Tronics with a return authorization number and a purchase order number. If the equipment is under warranty, repairs or a replacement will be made in accordance with the warranty policy set forth above. Please include a written explanation of all defects to assist our technicians in their troubleshooting efforts.

Call 800-492-1212 (inside the USA) or 610-777-1374 (outside the USA) for help identifying the Regional Service Center closest to you.